



Version 1.0

# Terra 23 – Terra 53 Charge Stations

## Installation Guide

## Notice

This document contains information about one or more ABB products and may include a description of or a reference to one or more standards that may be generally relevant to the ABB products. The presence of any such description of a standard or reference to a standard is not a representation that all of the ABB products referenced in this document support all of the features of the described or referenced standard. In order to determine the specific features supported by a particular ABB product, the reader should consult the product specifications for the particular ABB product.

ABB may have one or more patents or pending patent applications protecting the intellectual property in the ABB products described in this document.

The information in this document is subject to change without notice and should not be construed as a commitment by ABB. ABB assumes no responsibility for any errors that may appear in this document. In no event shall ABB be liable for direct, indirect, special, incidental or consequential damages of any nature or kind arising from the use of this document, nor shall ABB be liable for incidental or consequential damages arising from use of any software or hardware described in this document.

This document is originally written in English. Other language versions are a translation of the original document and ABB cannot be held liable for errors in the translation.

This document and parts thereof must not be reproduced or copied without written permission from ABB, and the contents thereof must not be imparted to a third party nor used for any unauthorized purpose.

## Copyrights

All rights to copyrights, registered trademarks, and trademarks reside with their respective owners.  
Copyright © 2014 ABB.  
All rights reserved.

# Table of Contents

Glossary	5
1 Introduction	6
1.1 Preface	6
1.2 Intended document users	6
1.3 Similarities and differences between Terra 23 and Terra 53	7
1.4 Terra version description	7
1.5 Signs	8
1.5.1 Owner responsibilities	9
1.5.2 Tilting and handling	9
1.5.3 Electric hazards	10
1.5.4 Installation safety	10
1.6 Environment and disposal of waste	11
2. Description of the product	11
2.1 Overview of the system	11
2.1.1 Complete overview	11
2.1.2 Outside view	12
2.1.3 Inside view	12
2.2 Geometry of infrastructure	13
2.2.1 Required space for placing and maintaining the Terra 53	13
2.2.2 Ventilation and airflow of the Terra 53	14
2.3 Electrical engineering	16
2.3.1 Requirements External RCD	16
2.3.2 Conductor and cable diameter	18
3. Site design	19
3.1 Cable reach	19
3.2 Different alignment possibilities	20
4. Site construction	21
4.1 About construction	21
4.2 Power feed	21
4.3 Construct foundation	21
4.3.1 Placement on soil	21
4.3.2 Placing the ABB Standard or locally manufactured prefab concrete foundation	21

4.3.3	Instructions for a custom foundation (footprint)	23
4.4	Power cable	23
4.5	Internet connection	23
5.	Receiving, Placing and connecting	25
5.1	Receiving the cabinet	25
5.2	Unpacking cabinet, mounting preparations	26
5.2.1	Unpacking	26
5.2.2	Mounting preparations	26
5.3	Move cabinet to position	28
5.3.1	Options	28
5.3.2	Move cabinet with hoist	28
5.3.3	Move cabinet with forklift truck	30
5.4	Mounting the cabinet	30
5.4.1	Mounting the cabinet.	31
5.4.2	Install cable gland(s)	32
5.5	Install border covers	33
5.5.1	Install border covers of cabinet	33
5.6	Connect cables	33
5.6.1	Connect PE of power cable	33
5.6.2	Connect power cable	34
5.6.3	Connect network cable	36
6.	Commissioning	37
6.1	Commissioning preparation	37
7.	Cleaning of the cabinet	39
7.1	Cleaning of the cabinet	39
8.	Technical Data	40
8.1	Electrical data	40
8.2	Mechanical data	41
8.3	Environment	41
8.4	Certifications	42

# Glossary

## AC

Alternating Current.

## Combo / CCS Combined Charging System

Combo is the name of a new charging protocol. Combo is the preferred charging protocol for NAM and European OEM's.

## Contractor

Entity hired by the owner / site operator to do engineering, civil and electrical installation work.

## DC

Direct Current.

## Grid provider

Company responsible for the transportation and distribution of electricity.

## HMI

Human Machine Interface; the screen on the charger.

## LTO

Low Temperature Option.

## NOC

ABB Network Operating Centre; remotely checks the correct functioning of the charger.

## Owner

The legal owner of the charger.

## PE

Protective Earth.

## PPE

Personal Protective Equipment.

Equipment such as safety shoes, helmet, glasses, gloves.

## RCD

Residual-Current Device.

## RFID

Radio-Frequency IDentification. RFID is a communication technology by means of radio waves to transfer data over a very short distance between a reader and an electronic tag or card.

## Site operator

The entity is responsible for the day to day control of the charger. The site operator can be the owner, but not necessarily.

## User

The owner of an electric vehicle, who uses the Charge Station to charge that vehicle.

# 1 Introduction

## 1.1 Preface

This guide describes the planning and physical installation of the Terra 23 or Terra 53 at its location.

The Terra 23 and Terra 53 Charge Stations are easy to install DC fast chargers for electric Vehicles. Fast chargers are electrical installations with high electric currents. Therefore the installation must be planned carefully, and must be done by certified personnel only (according to local standards).

The Terra 23 is physically the same charger as a Terra 53. The main difference is the output power it can deliver and therefore also the input power needed. The differences of the Terra 23 and Terra 53, and the consequences for the installation are described in a separate chapter.

As the physical installation of both types is equal, they will be referred to hereafter as Terra 53 only and this will account for both types, unless specifically stated otherwise.

Both types come in different versions, depending on the outlet types. The different versions are described in a separate paragraph.

## 1.2 Intended document users

This document is intended to be used by:

- Customers who purchased a Terra 53, or are in the process of ordering and want to know in more detail how it has to be installed.
- Contractors who are responsible for site preparation and/or installation of a Terra 23 or Terra 53.

### 1.3 Similarities and differences between Terra 23 and Terra 53

The Terra 23 and Terra 53 chargers are identical in their outer appearance and physical dimensions. The physical installation of the Terra 23 and 53 can thus be handled the same way.

On the inside of the cabinet there are some differences. The Terra 23 has a 20 kW DC power converter where the Terra 53 has a 50 kW converter. The Terra 23 can be updated to a Terra 53 in a later stadium if desired. Because of the possibility to upgrade, we advise to dimension the grid connection cable already to the power needed for a Terra 53, to prevent high costs for groundwork if a new cable has to be laid.

It is only possible to upgrade the DC power output of a Terra 23. The AC connector on a T23CJG will remain 22 kW after an eventual upgrade.

### 1.4 Terra version description

The Terra 23 and 53 are available in different versions depending on the available outlets.

The versions are:

Version	CCS	CHAdeMo	AC connector	AC socket
T53 C	X	-	-	-
T53 CJ	X	X	-	-
T53 CJG	X	X	X	-
T53 CT	X	-	-	X
T23 C	X	-	-	-
T23 CJ	X	X	-	-
T23 CJG	X	X	X	-
T23 CT	X	-	-	X

- C CCS (Combo) standard
- J CHAdeMO standard
- G AC connector 22/43 kW
- T AC Socket 22 kW

## 1.5 Signs

The following signs are used on the equipment and in this manual:



### **DANGER**

#### **Hazardous voltage**

Identifies a hazard that could result in severe injury or death through electrocution.



### **WARNING**

#### **Various**

Identifies a hazard that could result in severe injury or death.



### **WARNING**

#### **Rotating parts**

Identifies a hazard that could result in injury due to the presence of rotating or moving parts



### **WARNING**

#### **Pinch Hazard**

Identifies a hazard that could result in injuries in which some body parts are pinched or crushed



### **CAUTION**

#### **Various**

Identifies a hazard that could result in damage to the machine, other equipment, and/or environmental pollution



### **NOTICE**

Contains remarks, suggestions or advice.



### 1.5.1 Owner responsibilities

The owner and site operator are required:

- To operate the charge station with the protective devices installed and to make sure all protective devices are correctly installed after carrying out installation or maintenance.
- To write an emergency plan that instructs people what to do in case of emergency.
- To prepare the site where the charge station will be installed, according to the requirements described in this guide.
- To make sure that there is enough space around the charger to carry out maintenance work.
- To appoint a person responsible for the safe operation of the charge station and for the coordination of all work.
- The owner is cautioned that changes or modifications not expressly approved by ABB could void the owner's authority to operate the equipment and ABB's warranty policy
- Neither ABB nor its affiliates shall be liable to the purchaser of this product or third parties for damages, losses, costs or expenses incurred by purchaser or third parties as a result of: an accident, misuse or abuse of this product or unauthorized modifications, repairs or alterations to this product, or failure to strictly comply ABB operating and maintenance instructions.

### 1.5.2 Tilting and handling

	<b>WARNING</b>
	Heavy equipment
	The Terra 53 weighs about 350 kg. Handling Instructions: 1. Use crane, forklift or pallet truck when lifting or moving the Terra 53. 2. Do not drop the Terra 53. 3. Do not exceed a tilting angle of 30°.

### 1.5.3 Electric hazards



#### **DANGER**

##### **Hazardous voltage**

The Terra 53 contains conductors under hazardous electrical voltages. The grid terminals on the internal DIN rail may carry hazardous voltages, even if all circuit breakers are switched off.

### 1.5.4 Installation safety



#### **DANGER**

##### **Hazardous voltage**

Instructions:

1. Always switch off the external group switch and the main switch in the cabinet, before performing any installation, disassembly, repair or replacement of components.
2. Do a voltage check and make sure that the electrical power is disconnected from the system.
3. Only ABB certified technicians are permitted to commission the Terra.
4. When the system is in an open or dangerous condition, do not allow unqualified persons to go near it. Instruct and warn people about the potential harmful high voltages.
5. The installation and maintenance personnel must supply their own lighting equipment, since the T53 has no lights inside the cabinet.
6. Always connect the Protective Earth (PE) first, before connecting the neutral (N) and Phase (P) wiring.
7. Correctly lock the door after installation or service operations.

## 1.6 Environment and disposal of waste



### NOTICE

Always observe the local rules and regulations with respect to processing (non-reusable) parts of the Terra 53.

# 2. Description of the product

## 2.1 Overview of the system

### 2.1.1 Complete overview

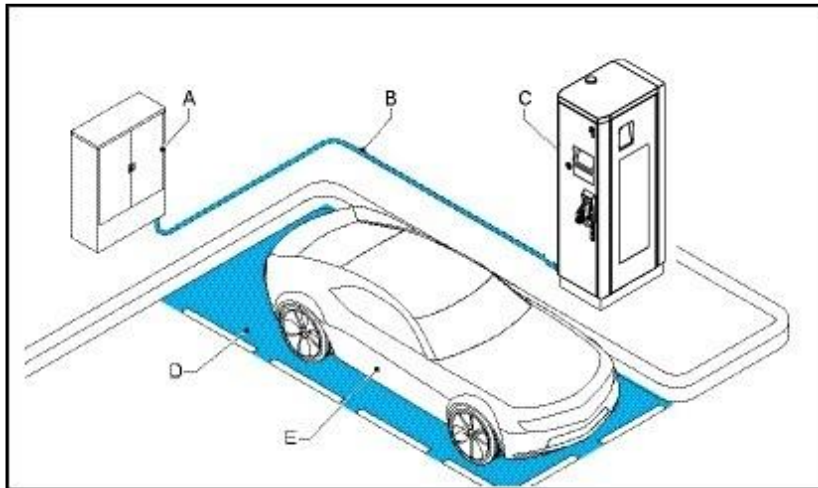

*Example of a complete installation*

- A Power distribution board of the owner
- B Cables in cable conduit (if required)
- C Terra 53
- D Parking space for charging
- E Electric vehicle

### 2.1.2 Outside view

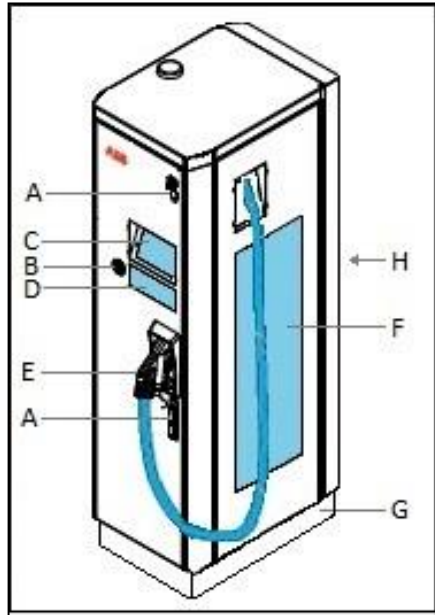

- |   |                    |   |  |
|---|--------------------|---|--|
| A | Door handle / lock | E | Charge outlet: DC connector and DC cable |
| B | Emergency stop     | F | Air inlet                                |
| C | Display / HMI      | G | Border cover                             |
| D | RFID card reader   | H | Air outlet (backside)                    |

### 2.1.3 Inside view

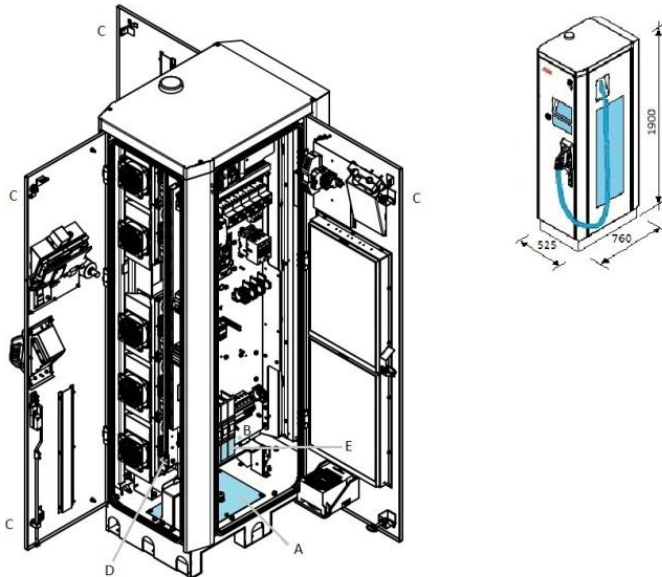

- |   |  |   |                   |
|---|--|---|-------------------|
| A | Cable gland plate                                    | D | Main switch       |
| B | PE connection  | E | Power connections |
| C | Door switch (2x on front door, 1x on each side door) |   |                   |

## 2.2 Geometry of infrastructure

### 2.2.1 Required space for placing and maintaining the Terra 53

The Terra 53 requires a space of 1550 x 1460 mm. This space is calculated as follows:

- Size Charger W x D x H: 530 x 760 x 1900 mm.
- Front side 600 mm, in order to open the front door.
- Left and right side 510 mm, in order to open left and right panel.
- Backside 100 mm, in order to guarantee an unimpeded airflow.

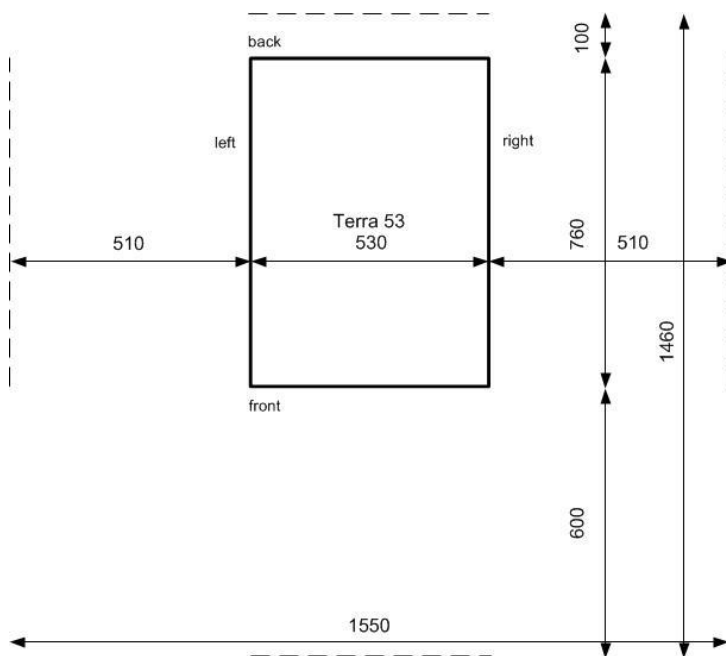

## 2.2.2 Ventilation and airflow of the Terra 53

The Terra 53 has an air inlet on the right side and outlet on the back side.



### NOTICE

#### Free air flow

If necessary, take precautions to prevent snow or objects from blocking the in- and outlets..

Top view:

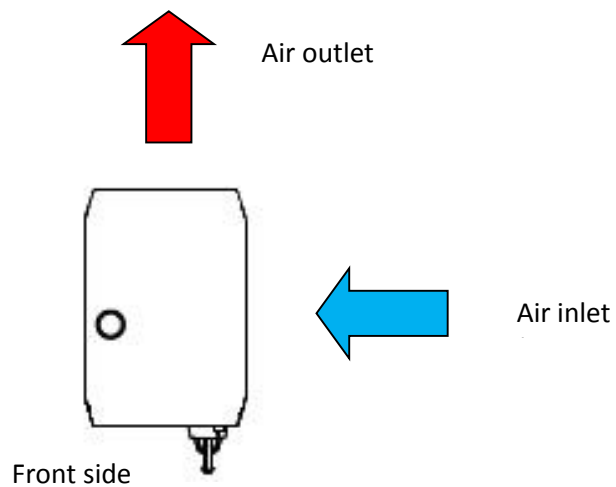

Angled front view:

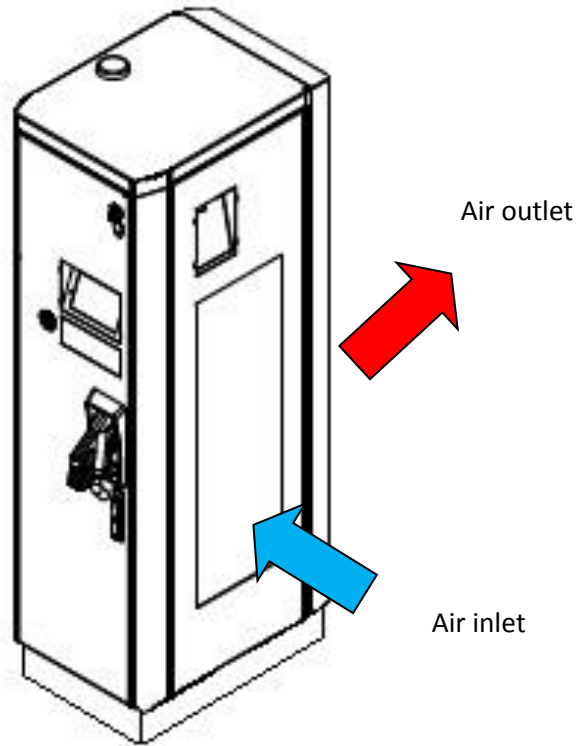

## 2.3 Electrical engineering

The electrical installation must be completed according to the local safety and electrical regulations and laws. A one-line diagram for the electrical connections with the main safety components inside the charger is shown in the figure below.

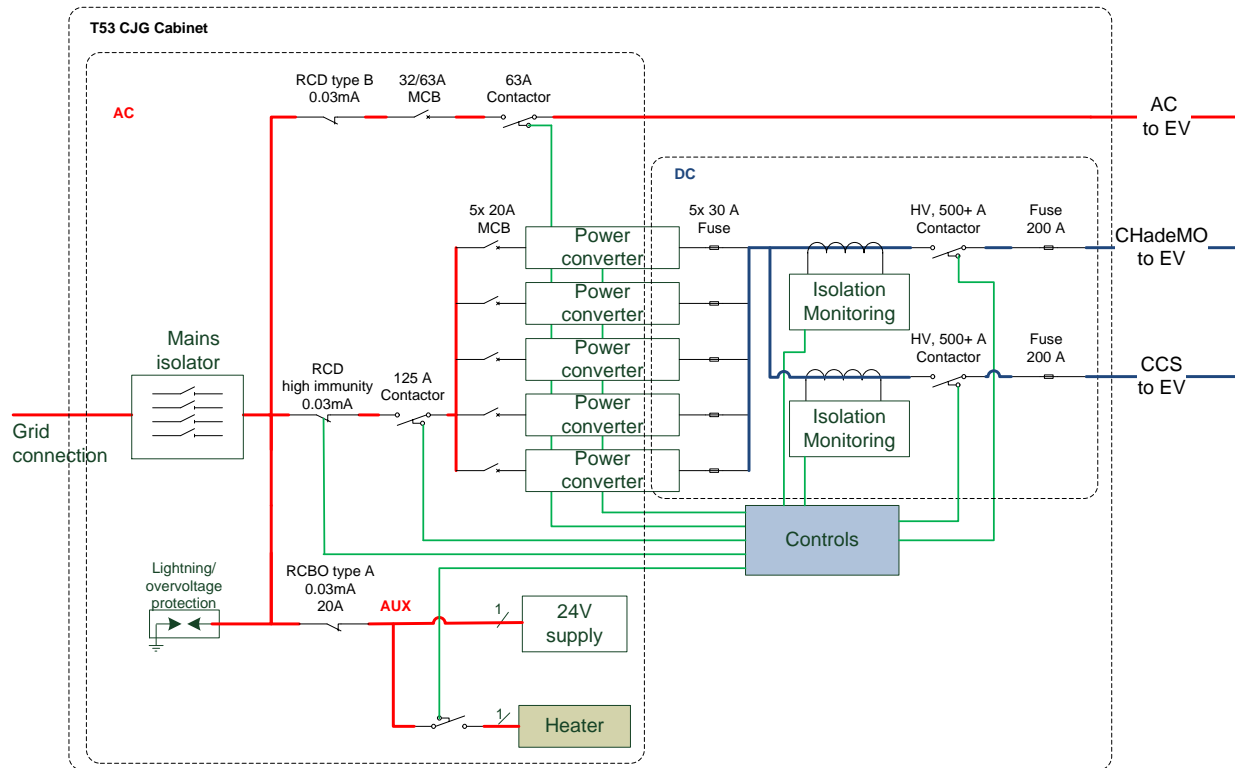

Figure 1 One-line diagram of the electrical connection and safety measures

### 2.3.1 Requirements External RCD



#### NOTICE

##### External RCD not included in delivery scope

Upstream RCD's are explicitly excluded from ABB's delivery scope and belong to the scope of the installation company. The locally certified installation company can base the RCD device type, amongst other external factors, on below charger characteristics

In case the local authorities prescribe the installation of an upstream RCD there is the following factors to take into account in selecting an RCD device of your choice.



## **AC-charging side prescribes Type B RCD**

In case your charger is equipped with an AC charging outlet indicated by the -T or -G in the type name, the following needs to be considered:

- The AC charging section of the charger has a RCD type B earth leakage protection. This protection is required to protect the person using the system from earth leakages, even while the onboard charger of the connected vehicle, independent from the charger functionality is causing DC currents in the AC-path towards the main switch of the charger or site distribution panel.
- Because of this Type B protection on the AC-side of the cabinet, most local installation procedures also prescribes a Type B RCD upstream if an upstream RCD is required. Your installation company is required to verify this requirement.

## **DC-charging side requires immunity for short current peaks over PE**

When the charger engages the DC charging (at the beginning every charger session in the pre charge phase) a relay switches and turns on the input to the power modules. A-synchronous engagement of the phases in the relay in combination with the electrical capacity in the input power part, can cause incidental very short (25 microseconds) current peaks of up to 60A over the Protective Earth. The amplitude of the Ampere peaks can vary with the location and is dependent on grid and earth impedance. Given the switching characteristics of the DC section of the charger we give you the advice to select an RCD that has proven to be able to withstand these short current peaks (high immunity). As a suggestion to the installation company ABB recommends the following RCD type which will work un most grid situations: (1) ABB make F204 B S-125/0,3 code: 2CSF204823R3950. It is the responsibility of your installation company to select the right device.

## **Local regulation could require a Type B upstream RCD independent of AC-charging functionality**

The design of the power section is such that a DC current over 6mA does NOT occur on the AC-input side of the power section during normal operation. In the event that small insects or dust would accumulate on a specific location in the cabinet (IP 54 rated) a pulsating DC leakage current can occur (with DC component above 6mA) such that the internal or optional external Type A RCD does not trip in the event of a (second fault) AC-phase to PE somewhere else in the system/installation. It is up to the local authorities to determine if these fault conditions qualify as independent single fault conditions and therefor require a Type B RCD.



#### **CAUTION**

##### **Responsibility to comply with local regulations**

The installation company is responsibly to design and install the electrical installation according the local regulations.

### **2.3.2 Conductor and cable diameter**

The diameter of the electrical conductor of the ground cables depends on the length, method of installation, etc. This must be determined by your contractor.

The phases and neutral are to be mounted with cable lugs M8 (not included in delivery) on the mains isolator. The maximum conductor surface is 95 mm<sup>2</sup>.



The maximum diameter of the (grid) cable entering the cabinet is 45 mm. The minimum diameter with the standard fitted cable gland insert is 34 mm.

**Figure 2 Example of cable lug to be used**

# 3. Site design

A site for EV charging can be designed in many different setups. This section is intended to give some useful information on the placement of a charger with respect to parking spaces and the vehicle inlets for the charging cable.

## 3.1 Cable reach

The charge cables of the T53 are about 3.9 meters long. The DC cables leave the charger on the right side, the AC cable leaves on the left side. The cables and the connectors mounted on the cables are different for each charging standard and make the more or less flexible to reach out.

The figure below shows the charger in the center with each type of connector and how far it can reach out. The yellow circle describes the range of the Combo cable, green circle the CHAdeMO cable, blue circle the AC cable

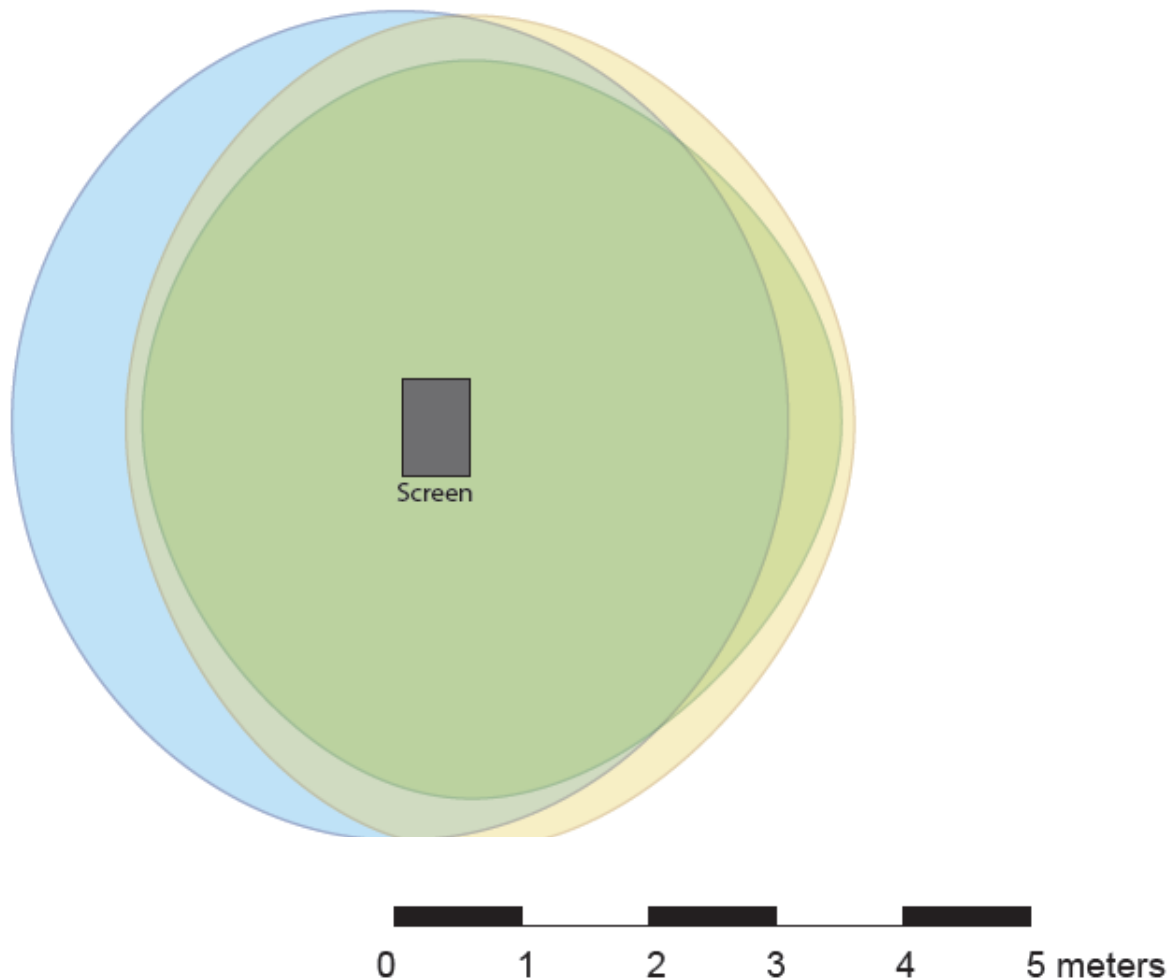

## 3.2 Different alignment possibilities

The charge inlets on a car can be located at different positions. The most common cars have their inlets located either on the front of the car, or on the left or right back side.

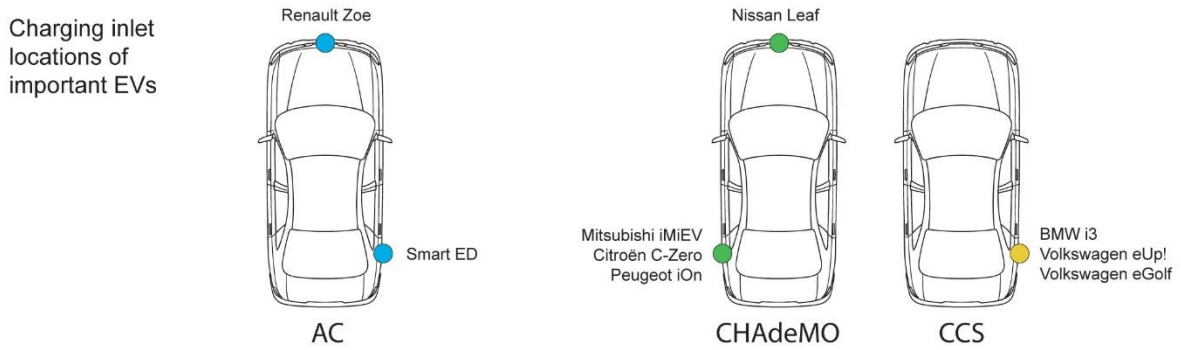

This makes some positions of the charger with respect to the parking space more favorable than others. Please keep this in mind when designing a site. Some possible situations are showed below:

### Forward parking

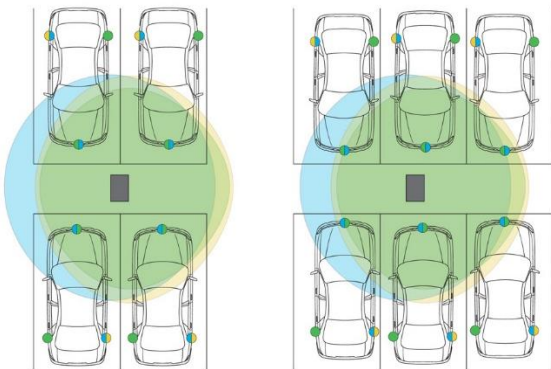

### Backward parking

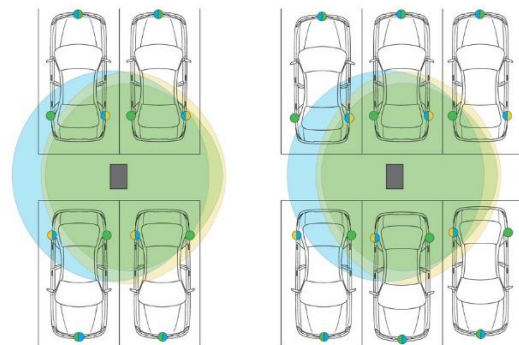

### Drive through

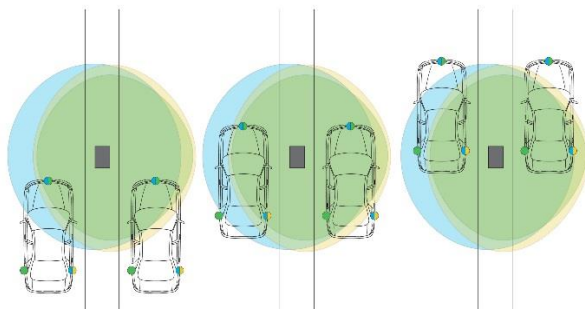

# 4. Site construction

## 4.1 About construction

The construction phase includes all work required to prepare the location and make it ready for the placement and connection of the Terra 53. The construction phase can start when:

- All preparation engineering work is done.
- All necessary permits are granted.
- The grid connection is available.

## 4.2 Power feed

The power cable enters the charger from below.

## 4.3 Construct foundation

The correct foundation depends on the type of surface where the Terra 53 will be installed.

### 4.3.1 Placement on soil

There are 2 options when the charger is placed on soil:

1. Use a prefab concrete foundation to get a firm fixation on soil.  
A prefab concrete foundation can be ordered separately, or produced locally according to the specifications.
2. The construction of a custom built foundation.

Depending on the situation and cable type, the cables must be embedded in the ground with or without a cable duct. See section Cabling on Page 23.

### 4.3.2 Placing the ABB Standard or locally manufactured prefab concrete foundation

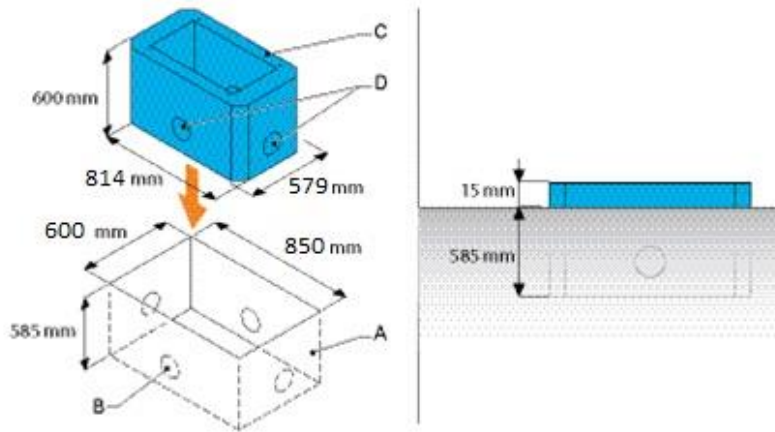

1. Make a hole in the ground (A) with a minimum of the dimensions shown.
2. Make sure the cable duct(s) are routed to one of the indicated positions (B).
3. Lower the foundation (C) into the hole.
4. Route the cables through one of the holes (D).
5. Make sure the top surface of the foundation is at least 15 mm above ground level to prevent water from entering into the charger foundation.
6. Make sure a cable length of one meter is available above the foundation for internal routing in the cabinet.
7. Fill the foundation with gravel or shingles to prevent rodents from entering the equipment.

### 4.3.3 Instructions for a custom foundation (footprint)

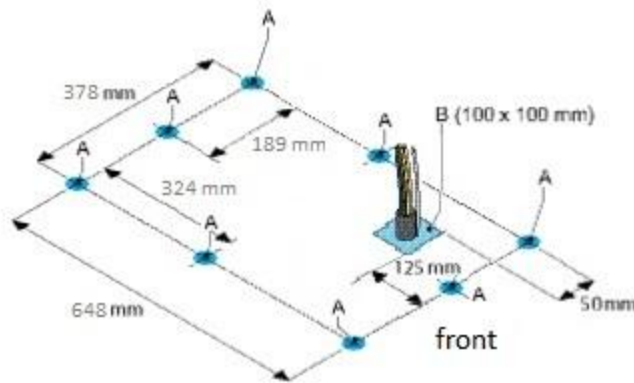

1. Drill and tap 8 holes (M10) in the floor at the indicated positions (A), depth  $\pm 60$ mm.
2. Make sure that the cables come out of the floor within the marked area (B).
3. Make sure that a cable length of one meter is available above the floor for internal routing in the cabinet.

## 4.4 Power cable

- Cable type: 3P+N+PE, shielded cables are optional if required by local law.
- The optional cable shielding must be attached to the PE Rail at both ends of the cable.
- The diameter of the cable conductor must be determined by your contractor / electrician.
- The maximum diameter of the cable conductor is 95 mm<sup>2</sup>.
- The PE conductor of the power cable must have the same diameter as the phase conductors.
- Recommended power cable: YMvKas mb 4 x 70 + 70 mm<sup>2</sup>.

## 4.5 Internet connection

The preferred method of communication is to use the wireless 2/3G modem that is integrated into the Charger. A customer SIM card is not required, a subscription for the SIM card is provided by ABB for selected countries.

If there is no wireless signal available, a standard wired internet connection is required. This connection must meet the following requirements:

- Ethernet, RJ45.

Cable type: 8P+PE, shielded.

Recommendations:

- for distances of 75 meters or less; HELUKAT 600E.
  - distances over 75 meters require a custom engineered project.
- Recommended minimum bandwidth:
    - upload: 128 kb/s
    - download: 4 mb/s.
  - Recommended availability: 99,9%.
  - The connection must be available for the ABB service engineer and the NOC.
  - Please contact ABB for a specific configuration.

In case the separate internet connection is not used, please assure the cable entry hole is closed, to assure the IP54 grade of the cabinet, and prevent insects and small insects to enter the cabinet.



# 5. Receiving, Placing and connecting

## 5.1 Receiving the cabinet

The product is delivered by a transport company to a warehouse where it will be handed over. Transporting the T53 to its final location (last mile service) is not standard included in the order.



### NOTICE

The delivery truck unloads the pallet carrying the Terra 53. The movement of the Terra 53 to its final location is the responsibility of the customer / contractor.

Check if the Terra 53 has not been shaken or tilted

- The cabinet is equipped with Shockwatch and Tiltwatch indicators.

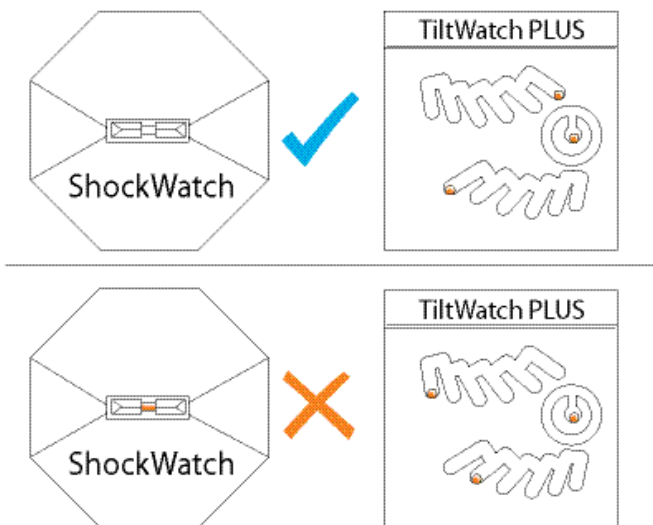

Checking the Shockwatch and TiltWatch PLUS sensors:

If the ShockWatch indicator is red, or the TiltWatch PLUS indicator is tilted over 30°:

1. Do not refuse the delivery / receipt.
2. Make a notation on the delivery receipt and inspect cabinet for damage.

3. If damage is discovered, leave cabinet in original package and request immediate inspection from carrier within 3 days of delivery.
4. Contact NLABB by mail ([service.evci@nl.abb.com](mailto:service.evci@nl.abb.com)) or phone (+3170 3076 201) to notify us about your findings.

## 5.2 Unpacking cabinet, mounting preparations

### 5.2.1 Unpacking

The packaging of the Terra 53 can be removed without the use of tools.



1. Remove the outside shrink wrap.
2. Remove the plastic protection profiles.
3. Remove the innerside shrink wrap.

### 5.2.2 Mounting preparations

1. Remove border covers

Preconditions:

- Tools: Allen key size 4.

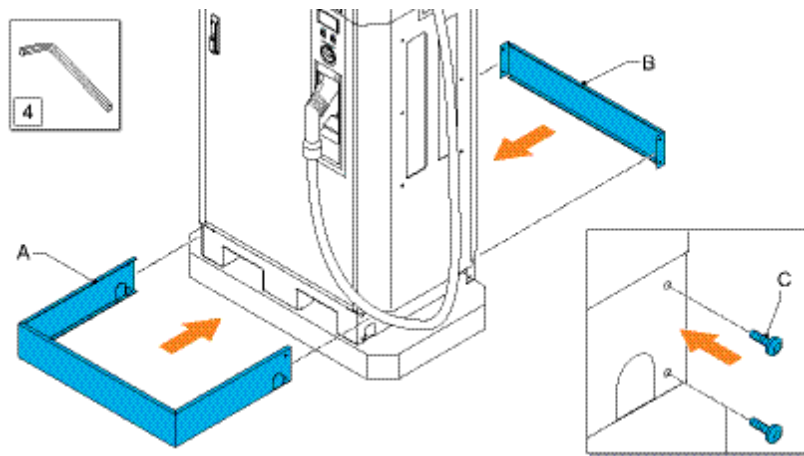

1. Remove the bolts (C) of the border covers.
2. Remove the U-shaped covers (A, B) off the base of the Terra 53.

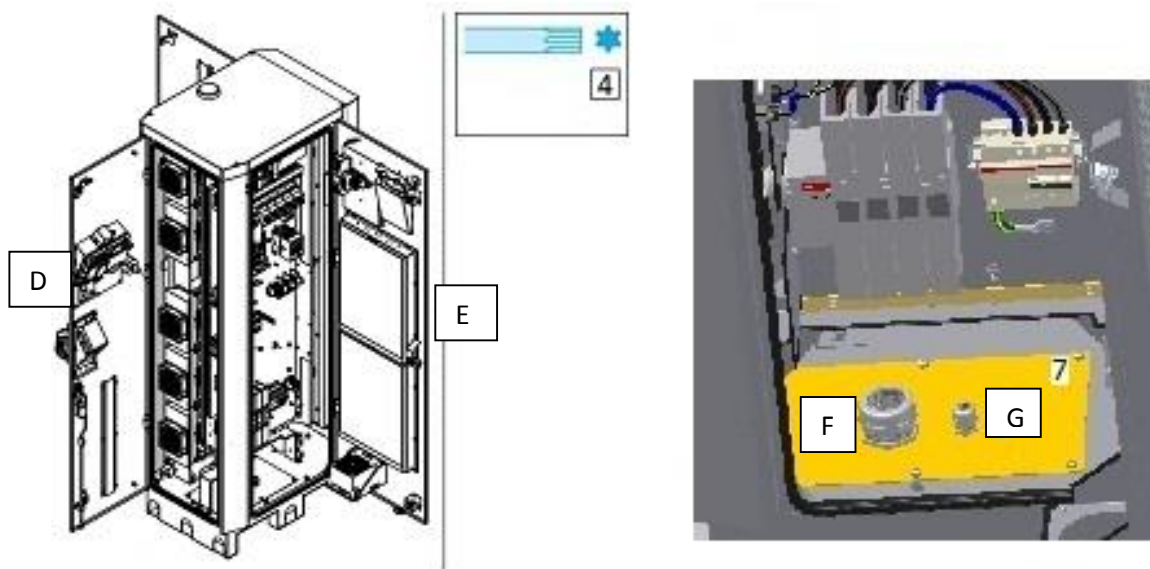

3. Open the cabinet front door (D).
4. Open the side door (E) via the front door.
5. Loosen and remove the cable gland (F) for the powercable.
6. Loosen and remove the cable gland (G) for the Ethernet cable (if required).
7. Put the cable gland(s) in a safe location. It (they) will be re-installed later.
8. Close the doors, starting with the side door and subsequently the front door.

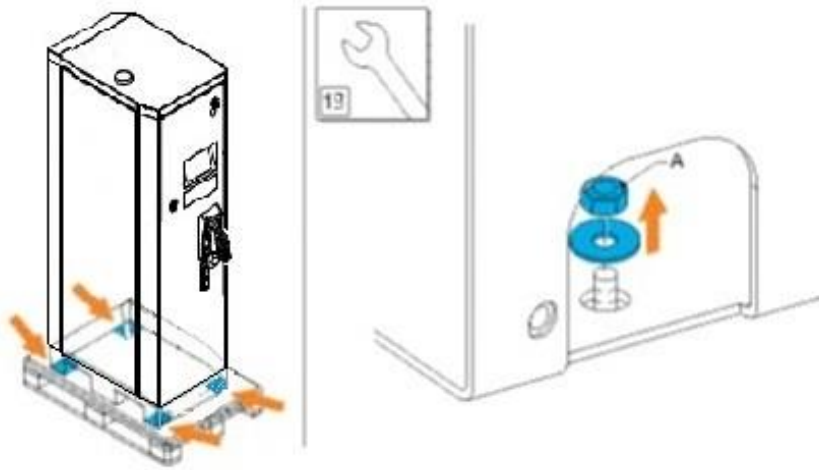

10. Remove the nuts (A) at the four corners.

## 5.3 Move cabinet to position

### 5.3.1 Options

There are two options to move the Terra 53 from the delivery truck to the location.

- Move cabinet with hoist on Page 28
- Move cabinet with forklift truck on Page 30



#### **DANGER**

##### **Hazardous voltage**

Make sure the main switch of the power supply group for the product is set to the OFF position. Do a voltage check to make sure there is no electrical power on the cables or on the system.



#### **NOTICE**

##### **Warranty**

Damage due to moving the cabinet to its position is not considered a warranty issue.

### 5.3.2 Move cabinet with hoist

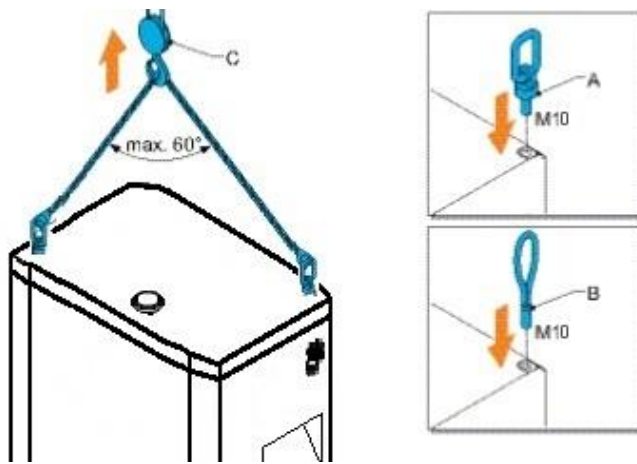

- A Swivel eye bolts
- B Lifting loops
- C Hoisting equipment

Preconditions:

- Use swivel eye bolts (A) or bolts with lifting loops (B).
1. Insert and tighten the bolts (A) or (B) at opposite corners.
  2. Connect the hoisting equipment (C).
  3. Move the Terra 53 carefully to its location.



**WARNING**

**Various**

Keep the hoisting angle below 60°.

Swivel eye bolts, lifting loops and hoisting equipment are not part of the delivery

## Move cabinet with forklift truck

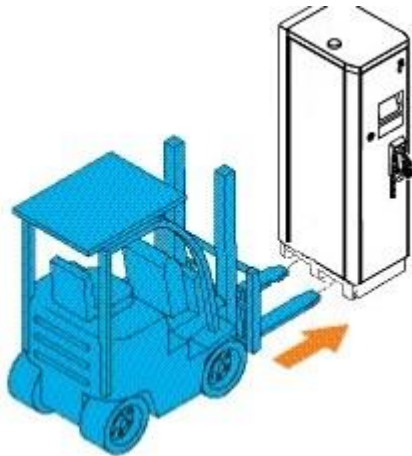

1. Move the forks of the forklift truck in the gaps at the side of the Terra 53.
2. Move the Terra 53 carefully to its location.

## 5.4 Mounting the cabinet

Preconditions:

- Tools: Spanners size 17.
- The Terra 53 is about 0.5 m above its location
- Open the front door and right side panel.
- Guide the powercable through the cable gland and if required the Ethernet cable through the smaller gland.

#### 4.4.1 Mounting the cabinet to a foundation

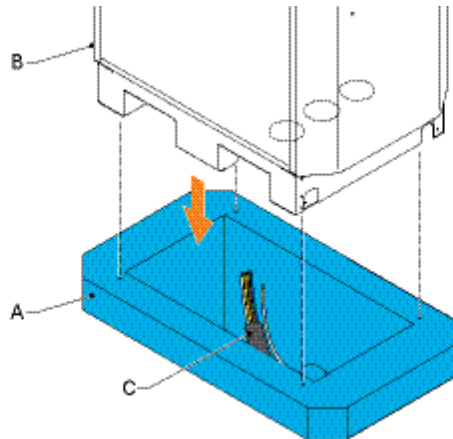

Placement on a concrete foundation

- A Foundation
- B Terra 53
- C Cables

#### 5.4.1 Mounting the cabinet.

1. Carefully lower the Terra 53 onto its location.
2. Make sure not to entrap the cable(s).
3. Make sure that the cabinet is aligned to the tapped holes.

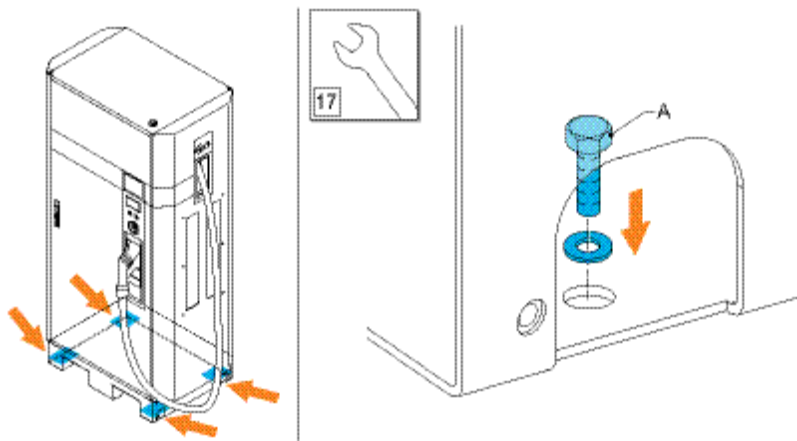

4. Insert bolts (A) and washers at the four corners and in the middle of the sides.
5. Tighten the bolts.

### 5.4.2 Install cable gland(s)

The maximum diameter of the grid cable is 45 mm.

The minimum diameter of the grid cable is 34 mm with the standard fitted cable gland insert.



1. Slide the cable gland(s) over the cable(s).
2. Push the cables back through the gland plate, until sufficient cable length is left to reach the cable terminals, make sure the PE cable is longer than the other cables.
3. Tighten the rings of the gland(s).



## 5.5 Install border covers

### 5.5.1 Install border covers of cabinet

Preconditions:

- Tools: Allen key size 4.

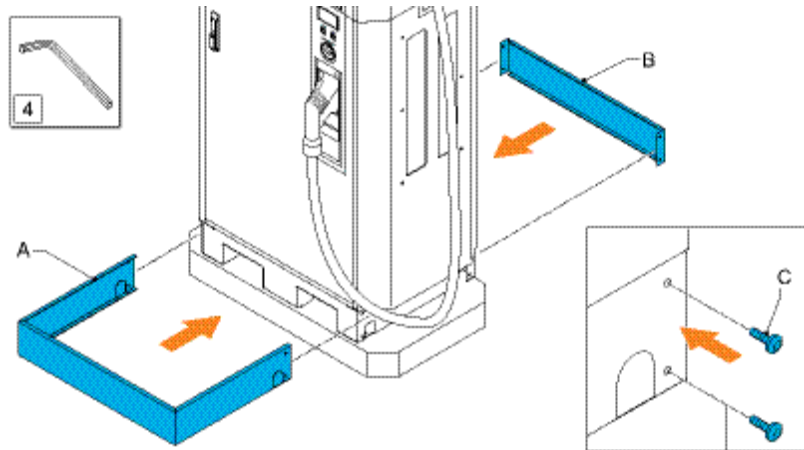

1. Put the small cover (B) against the back of the Terra 53.
2. Put the U-shaped cover (A) on the base of the Terra 53 from the front. The U-shaped cover overlaps the sides of the small cover.
3. Insert and tighten the bolts (C) at both sides.

## 5.6 Connect cables

### 5.6.1 Connect PE of power cable

Preconditions:

- Tools: Wire stripper pliers; wire-end lug pliers; wire-end lug.



#### **DANGER**

#### **Hazardous voltage**

Make sure that the main switch of the power supply group for the product is set to the OFF position. Perform a voltage check and make sure that the electrical power is disconnected from the system



1. Cut the PE wire of the power cable to the correct length to reach the PE connector.



#### **NOTICE**

For safety, it is recommended to make the PE wire longer than the phase wires. This makes sure that the PE wire stays connected as longest, if the Terra 53 is moved by a collision

2. Use wire stripper pliers to remove 20 mm of the insulation from the end of the PE wire.
3. Attach a cable lug to the end of the PE wire.
4. Loosen the bolt of the PE connector.
5. Attach the PE wire onto the PE connector.
6. Tighten the bolt.

### **5.6.2 Connect power cable**

Preconditions:

- Tools: Wire stripper pliers; wire-end lug pliers; wire-end lugs.



#### **DANGER**

Make sure that the main switch of the power supply group for the product is set to the OFF position. Do a voltage check and make sure that the electrical power is disconnected from the system.



1. Cut the 3 phase and neutral wires of the power cable to the correct lengths to reach the connectors.
2. Use wire stripper pliers to remove 20 mm of the insulation from the ends of the wires and attach the cable lugs.
3. Pull the covers away from the connectors and remove them.
4. Loosen the bolts of the connectors.
5. Attach the four wires onto their connectors.
  - From left to right:  
L1 (brown) at position 2,  
L2 (black) at position 4,  
L3 (grey or black) at position 6,  
0 (blue) at position 8.
6. Tighten the bolts.
7. Install the covers back onto the connector.



**WARNING**

Leave the main switch switched off. The Terra 53 is not ready for use yet. Please contact the ABB Service department at least one week in advance to make an appointment for commissioning.

### 5.6.3 Connect network cable



#### **NOTICE**

Only connect the network cable if a wireless 2G/3G connection is not possible.

#### Preconditions:

- Tools: Network cable pliers, RJ45 connector; network cable straight,
1. Cut the network cable to the correct length to reach the Ethernet connector.  
The connector is located behind the right side door, near the bottom of the charger.
  2. Use network cable pliers to install an RJ45 connector on to the network cable.
  3. Insert the RJ45 connector into the Ethernet connector.

# 6. Commissioning

## 6.1 Commissioning preparation

Commissioning is the last phase necessary to get the Terra 53 operational. The purpose is to check the safe functioning of the charger for its operational purpose.

A certified service engineer from the ABB Service department or a trained engineer by ABB is required to perform the commissioning. During this commissioning the safety and the functioning of the charger will be tested.

Before the service engineer can start, the following conditions must be met:

- All work described in Preparation (starting page 13), Construction (starting page 19) and Placement and connection (Starting page 25) is done.
- Power is available.
- A local technician is present for assistance and to switch on the power.
- Internet access must be available in case 2/3G is not functional.
- A Combo compliant electric vehicle must be available for testing CCS charging.
- A CHAdeMO compliant electric vehicle must be available for testing the CHAdeMO charging.
- A AC compliant electric vehicle must be available for testing AC charging.
- Any electric vehicle for instructing the site operator.



### NOTICE

#### Warranty

It is not allowed to move the Terra 53, after it is commissioned.

In case the Terra 53 is moved without contacting ABB, the warranty will be considered void. In case of relocation please contact the local ABB Service department

Commissioning is executed according to the Check list, this checklist can be found in the Helios Suite Service tool that is available to the certified commissioning engineers or their supervising ABB organisation. Also the following data is required for input:

- End-user Contact person (Create a contact if it doesn't exist)
- Charger address (Check the mentioned address, it will be the address the charger was shipped to)

- Coordinates longitude and latitude for plots on the maps. If there are more chargers on 1 location, make sure the coordinates are slightly different (at least 0,0001 degrees) to prevent being displayed on the same location.
- Site name if this is useful for better recognition (eg Shell petrol station Amsterdam),
- External fuse of the charger
- SAT date
- Location remarks (any special remarks about the site, eg behind a gate, no photo camera's allowed etc.)
- Add a picture of the surrounding of the charger, upload the local CAF document A4 on the page of the charger in PDF
- Change Deliver status to <SAT>.

After completing the Site Acceptance Test, ABB's Network Operation Center will be triggered to perform a final check on the connection and configuration of the charger.

Upon approval the charger will be operational and initialized for use.

# 7. Cleaning of the cabinet

## 7.1 Cleaning of the cabinet

The Terra 53 Charge Station is powder coated. This coating must be kept in good condition. Clean the Terra 53 Charge Station three times a year in the following way:

- Remove rough dirt by spraying with low-pressure tap water.
- Apply a neutral or weak alkaline cleaning solution and let it soak.
- Remove dirt by hand with a non-woven nylon hand pad.
- Rinse thoroughly with tap water.
- Optionally, apply wax on the front for extra protection and gloss.
- Do a check on the coating for damage.



### NOTICE

When the Terra 51 Charge Station is exposed to rain, it is sufficient to clean it twice a year.



### CAUTION

Do not apply high-pressure water jets. Water may leak into the Terra 53 Charge Station. If a high-pressure water jet has been used, make sure that the inside of the Terra 53 Charge Station is dry.

- Only use cleaning agents with a pH value between 6 and 8.
- Do not use cleaning agents with abrasive components.
- Do not use abrasive tools.

# 8. Technical Data

## 8.1 Electrical data

<b>Input</b>	
Supply voltage	3 phase, 400 V AC: PE, N, L1, L2, L3
Input voltage range	400 V AC +/- 10% (50 Hz or 60 Hz)
Maximum rated input current & power	125 A, 86 kVA
Power factor	> 96%
Efficiency	95% at nominal output power
<b>DC output (C)</b>	
Maximum output power	50 kW
Output voltage range	200 – 500 V DC (Combo-2)
Maximum output current	125 A DC +/- 5% (Combo-2)
<b>DC output (J)</b>	
Maximum output power	50 kW
Output voltage range	50 – 500 V DC (CHAdeMO)
Maximum output current	120 A DC (CHAdeMO)
<b>Option: AC output socket (T)</b>	
Maximum output power	22 kW
Max AC output current	3 x 32 A
Output Voltage Range	400 V +/- 10%
<b>Option: AC output Cable (G)</b>	
Maximum output power	22 kW / 43 kW
Max AC output current	3 x 32 A / 3 x 63 A
Output Voltage Range	400 V +/- 10%



<b>General</b>	
DC connection standard	EN61851-23 / DIN 70121 Combo-2 CHAdeMO 1.0
DC cable length	3.9 meters +/- 10%
DC plug type	COMBO-2 / JEVS G105 CHAdeMO
AC connection standard	EN61851-1:2010 (Renault / Daimler compatible)
Option: connector type	IEC62196 mode-3 type-2
<b>RFID data</b>	
RFID system	FeliCa™1, NFC reader mode
<b>Network connection</b>	
	GSM / CDMA modem 10/100 Base-T Ethernet

## 8.2 Mechanical data

<b>Mechanical data</b>	
Dimensions (H x W x D)	1900 mm x 525 mm x 760 mm
Weight	325 kg
Volume	0,76 m <sup>3</sup>
Dimensions including packaging (H X W x D)	2100 mm x 1200 mm x 800 mm
Weight including packaging	350 kg
Weight concrete foundation	400 kg
Mechanical impact protection	IK08
Housing	Stainless steel 430

## 8.3 Environment

<b>Environmental data</b>	
Ingression protection	IP54
Temperature range – Operation	-10 °C to +50 °C (without LTO)

	-35 °C to +50 °C (with LTO)
Temperature range - Storage	-40 °C to +70 °C
Humidity	20% - 95% RH - non-condensing
Operational noise level	45 dBA
Altitude	2000 m max.

## 8.4 Certifications

CE Certification ????.

ISO/IEC14443A/B, ISO/IEC15693,